PSI Audio User Manual

TABLE OF CONTENTS

1	INTRODUCTION.....	3
2	SAFETY INSTRUCTION.....	3
2.1	WARNINGS	3
2.2	SERVICE.....	4
3	GENERAL OVERVIEW	4
3.1	BEFORE YOU START	4
3.2	FRONT PANEL DESCRIPTION	5
3.3	REAR PANEL DESCRIPTION	5
4	QUICK START.....	6
5	OPERATION	6
5.1	POWER ON LED (GREEN).....	6
5.2	OVERLOAD / OVERHEAT LED (RED).....	6
5.3	AUDIO SIGNAL INPUT CONNECTOR	7
5.4	PSC COMMAND PRINCIPLE	7
5.5	LEVEL / INPUT SENSITIVITY POTENTIOMETER	7
5.6	ROLL-OFF POTENTIOMETER	7
5.7	VOLTAGE SELECTOR / MAINS FUSE.....	7
6	INSTALLATION.....	7
6.1	ENVIRONMENT	7
6.2	ROLL-OFF SIMPLIFIED THEORETICAL VIEW :	7
6.3	ROLL-OFF PRACTICAL VIEW :	8
6.4	MOUNTING	9
	PLEASE RESPECT THE INSTRUCTIONS GIVEN IN THE “TECHNICAL DATA SHEET” OF EACH PRODUCT.....	9
6.5	STEREO OPERATION	9
6.6	STEREO + SUB OPERATION	9
6.7	MULTI CHANEL 5+1 OPERATION	11
7	TROUBLESHOOTING	11
7.1	POWER ON LED DOES NOT LIGHT UP.....	11
7.2	UNBALANCED TO BALANCED OPERATION.....	12
7.3	POOR AUDIO QUALITY	12
7.4	UNEVEN FREQUENCY RESPONSE	12
8	C.E. & ROHS CONFORMITIES.....	12
9	WARRANTY.....	12

1 Introduction

Thank you very much, and congratulations on your decision to purchase a professional monitoring system from PSI Audio.

Carefully following the instructions in this manual will ensure that your loudspeaker system will give you many years of reliable and trouble free operation.

For the latest information, help or advice, please contact your local PSI Audio representative or PSI Audio directly.

Relec S.A.
Rue des Petits Champs 11 a+b
CH-1400 YVERDON (Switzerland)
Tel : +41 (0)24 426 0420
Tel : +41 (0)24 426 0451
E info@psiaudio.com
W www.psiaudio.com

2 Safety Instruction



This symbol alerts the user to the presence of electrical power within the product that may be of sufficient magnitude to constitute a risk of electric shock.



This symbol alerts the user to important operating and maintenance (servicing) instructions or warnings.

2.1 Warnings

- Please read and follow the instructions carefully prior to operation of the loudspeaker.
- Please do not open the loudspeaker - risk of electric shock.
- Make sure not to expose the loudspeaker to any form of liquids. For cleaning purposes use only a dry cloth. In order to prevent spills, do not place any containers containing liquid on the loudspeaker. Do not use the speaker close to water as this may create a shock hazard.
- Only use three wire mains cables and connectors with earthing (grounding) according to your country standard.
- Check your AC voltage and make sure that the voltage setting and fuse on the rear of the chassis are set correctly.
- Do not operate the speaker in a confined environment (i.e. in a flight case) The rear panel of the speaker should be open and permit appropriate circulation and ventilation of air for cooling purposes. Make sure all ventilation openings are free of any obstacles.

-
- Do not operate or install this speaker near any kind of heat source.
 - Only operate this speaker with accessories specified by PSI Audio.
 - For maximum operating safety, the loudspeaker should be used with a three-wire AC power system. Two-wire operation may cause a potential hazard.

2.2 Service



The loudspeaker contains no user-serviceable parts. Service must be performed by qualified personnel. The primary fuse must be replaced by exactly the same type and rating. The unit must not be opened by the user – risk of a severe electric shock.

Servicing is required when :

- the speaker has been damaged in some way, such as when the power-supply cord or plug is damaged,
- the loudspeaker has suffered from exposure to rain or moisture,
- liquid has been spilled into the loudspeaker,
- objects have been dropped into the loudspeaker,
- the loudspeaker does not work correctly.

Spare part supply :

- For ordering, please contact your authorized dealer, mentioning your loudspeaker model and serial number (see point 3.3.).

3 General Overview

3.1 Before you start

Special care has been taken in the packaging of your PSI Audio equipment. Before you start to install it, please check that the following parts are included :

- Loudspeaker
- Individual frequency response diagram
- Data sheet
- PSI AUDIO User Manual (this manual)
- Additional stickers according to model

3.2 Front Panel Description

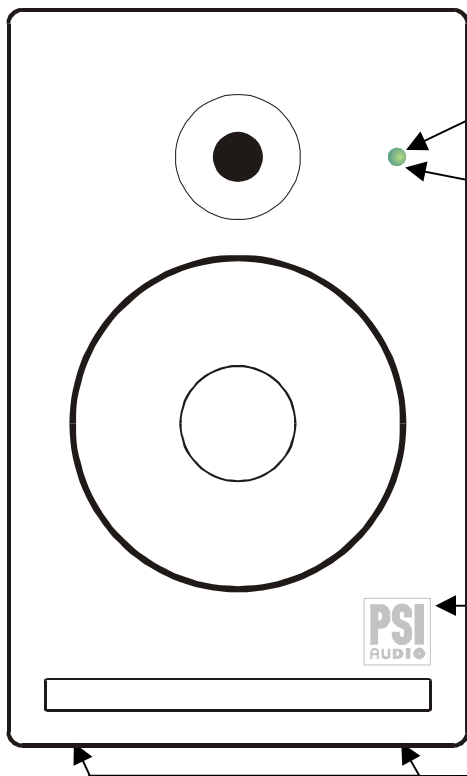

Power ON LED (Green)

Mains power is present and the speaker is ready to use.

Limiter or Overheat or Standby LED (Red)

Flashing of the led indicates that the internal limiter is working.

If the LED works continuously, the amplifier is operating under overheated conditions and turns into standby mode.

Suggestion for additional logo placement

Anti-slippage stickers to be placed underneath the unit.

3.3 Rear Panel Description

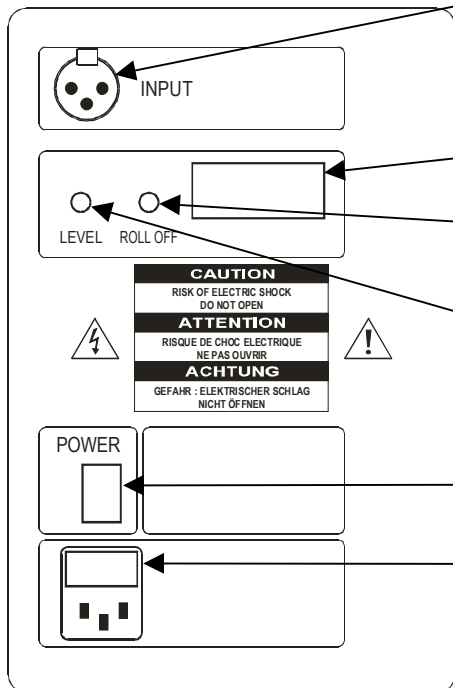

Audio Signal Input Connector

Female XLR with the following wiring convention :
 1 = Chassis (Ground)
 2 = + Hot
 3 = - Cold

Model : PSI Audio XX-M
 Serial : N°XXXXXXXX

Roll-Off Potentiometer

Aligns the low frequency response to room conditions.

Level / Input Sensitivity Potentiometer

Audio input signal calibration

Power On / Off Switch

Voltage Selector / Mains Fuse

Selects AC voltage and fuse value

4 Quick Start

We recommend that you spend some time setting up your monitoring speaker system. Setting up naturally takes a certain amount of time. However, in case you need to get started quickly, please follow the quick set up guide. The rest of this manual will assist you in setting up your loudspeaker system and calibrate it according to your listening environment.

- Check that the voltage value on the AC power selector is set correctly (according to your local AC power supply). If this is not the case, it will be necessary to adjust the main power supply with the following procedure. Carefully squeeze the two latches on either side of the fuse plug and pull the fuse holder out of its socket. Now replace the fuse for the different voltage setting with the correct value fuse according to the required voltage. The correct value of the fuse is printed next to the On-Off switch of your loudspeaker. Pull out the grey plastic cap which holds the fuse and turn it 180° so it shows the correct voltage setting through the outer window when placed back in its position. Now you can carefully push the complete fuse holder back into its place above the mains connector.
- Connect the live cable whilst paying attention to the warnings mentioned under the chapter safety instructions.
- Verify that no audio signal is being sent to the loudspeaker and turn the power switch to ON. The green led on the front panel will now illuminate.
- Connect the audio source (line signal) from your mixer, preamplifier or other equipment to the XLR connector at the rear.
- Turn the Level (input sensitivity) potentiometer fully clockwise.
- Verify that the Roll-Off potentiometer is turned fully clockwise in order to provide a flat frequency response to start with.
- Set the loudspeaker level potentiometer to the CAL position (CALIBRATED) and fade in the signal source as required.
- Normal operating conditions will cause the red led to flash occasionally on peaks. We draw your attention to the fact that this loudspeaker can produce pressure levels which may be harmful. PSI Audio declines all responsibility for eventual hearing loss caused by the use of their loudspeakers.

5 Operation

5.1 Power ON LED (Green)

The green LED on the front panel shows that the loudspeaker is operational. In the event that this LED does not light up, verify that the loudspeaker is connected to the AC power outlet and/or check the fuse.

5.2 Overload / Overheat LED (Red)

The red LED indicates the operation of the internal limiter and during normal operation, the light flashes when the modulation peak has reached a modulation peak of 1dB. If the LED flashes regularly, this means that overload conditions are met and you should reduce the input level.

If the red LED stays continuously illuminated, this means that the amplifier is in overheated conditions, and the components are at risk of being damaged. Turn off the AC power immediately.

Typical causes of overheat are lack of ventilation. Check that sufficient air flow is available around your loudspeaker. Close proximity of overheated sources may also cause overheating.

5.3 Audio Signal Input Connector

The female XLR connector on the rear panel provides a balanced analogue input with the following wiring conventions :

- 1 = Chassis (Ground)
- 2 = + Hot
- 3 = - Cold

When using the loudspeaker with unbalanced sources, the following wiring conventions may be used

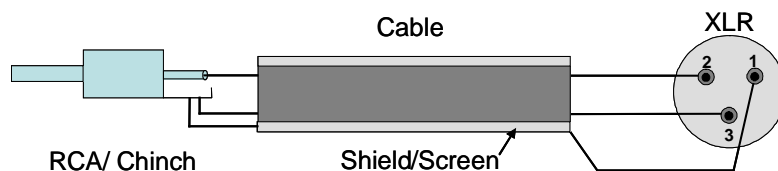

5.4 PSC Command principle

PSC enables to control the standby mode of your loudspeakers through the signal cable. This command is generated by pulling up simultaneously the voltage of the entries (2) and (3) of the XLR. A voltage of +5 to 25V DC referenced to the ground is necessary to control the standby mode.

The front panel LED is slightly lit in red during the standby mode.

For more information about the PSC principle, please refer to our website directly : www.psiaudio.com, section Technologies.

5.5 Level / Input Sensitivity Potentiometer

The level is continuously variable, the potentiometer controls the logarithmic converter whose precision is greater than 1 dB.

5.6 Roll-Off Potentiometer

See installation section 6

5.7 Voltage Selector / Mains Fuse

See point 1 in the Quick Start section 4.

Cooling space :

always make sure that sufficient air flow is available around your loudspeaker to prevent overheating.

6 Installation

6.1 Environment

PSI Audio loudspeakers are calibrated to give a flat response under free field conditions. The acoustic environment will naturally influence the overall performances of the loudspeakers.

When using the loudspeaker in a studio environment, the Roll-Off control allows the low frequency response to be tailored according to the position of the loudspeaker. Placing a speaker in a corner or near a wall will affect the bass response and this can be compensated by the use of the calibration controller.

6.2 Roll-Off simplified theoretical view :

If a sound source is omni-directional and incorporated into a wall, it radiates into a half space. The generated acoustic pressure is doubled (+ 6 dB) in comparison to free field radiation.

For high frequencies, the wavelengths are shorter than the dimension of the loudspeaker. Therefore, the enclosure determinates the radiation pattern.

For low frequencies, the wavelengths are longer than the dimension of the loudspeaker. The position and the material of room partitions which determinates the radiation pattern.

When a loudspeaker is not used in free field mode, the « Roll Off » calibration must be applied.

6.3 Roll-Off practical view :

Even at very low frequencies, a monitor is not really omni-directional, and it cannot be completely incorporated into a partition. Consequently, the acoustic pressure level will not be entirely doubled by the partition.

Roll Off Calibration	Simplified theory	Practical adjustment	
Full space (free standing)	0 dB	Cal	Figure 1
Half space (wall mounting)	-6 dB	~ - 4 dB	Figure 2
Quart space (corner mounting)	-12 dB	~ - 7 dB	Figure 3

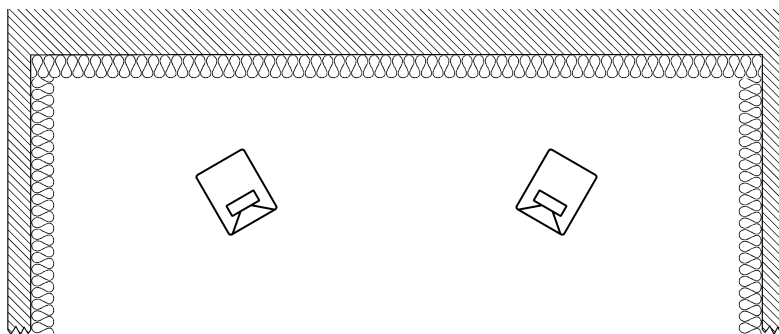

Fig 1 – Full space : Roll off @ cal. Point

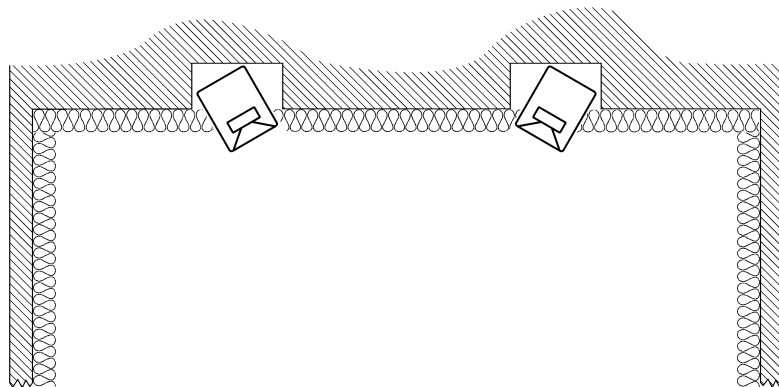

Fig 2 – Half-space : Roll off @ ~ - 4dB

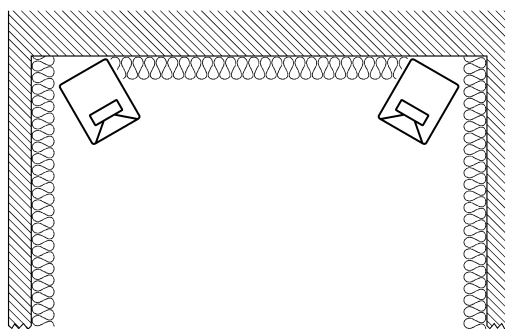

Fig 3 – Quart-space : Roll off @ ~ - 7dB

6.4 Mounting

Please respect the instructions given in the "Technical Data Sheet" of each product.

6.5 Stereo Operation

Position the loudspeakers so that the position between the listener, the left and right loudspeakers determine an equilateral triangle. The acoustic axis (see the Technical datasheet of your PSI audio monitor) should be at ear height or slightly higher. This is valid for any music listening mode (stereo, multichannel, etc..).

6.6 Stereo + Sub Operation

For music listening, the role of the subwoofer is to extend the low frequency response and the maximum sound pressure level in a linear fashion. The placement of a subwoofer, especially in a small control room, can be critical. It is recommended that the user takes some time to find the optimum position.

Calibration procedure

The monitor Roll Off is positioned at -10dB .

The subwoofer is placed on the floor.

The distance from the subwoofer to the listener is equal to the distance from the monitor to the listener ($\pm 0.5\text{m}$).

Because of its complementary response, the largest part of very low frequencies are spread by the subwoofer.

- **Subwoofer level calibration:**

The first monitor is temporarily positioned in free standing, and the signal is directly applied.

Level : Cal

Roll Off : Cal

The second monitor and the subwoofer are placed at their normal positions, and the signal is applied through the subwoofer.

Level : Cal

Roll Off : -10dB

Signal : 70 @ 150 Hz (i.e. cello low note)

- When commuting the first direct monitor or the second together with the subwoofer, the sound level hearing comparison allows a reliable and objective adjustment (± 0.5 dB). When adjusting the subwoofer level, the two systems should provide the same sound impression.

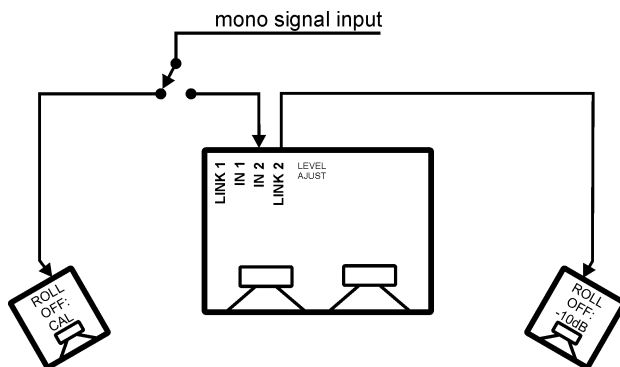

Stereo & sub system calibration

- The sub level being now calibrated, the signal from the first monitor should go through the sub and its Roll-Off adjusted @ -10dB

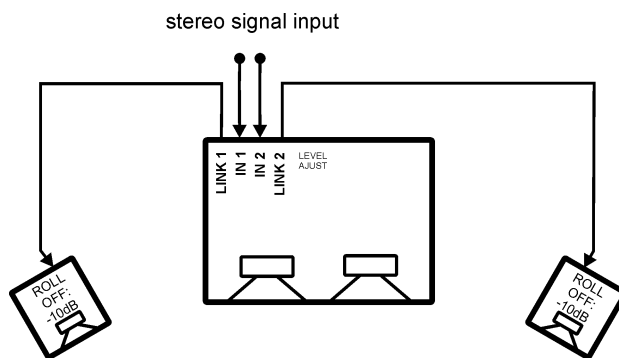

Stereo & sub system in practice

6.7 Multi channel 5+1 Operation

Installation in multichannel covers a wide field of applications and different requirements have their own criteria.

- **Music & Home Cinema playback**

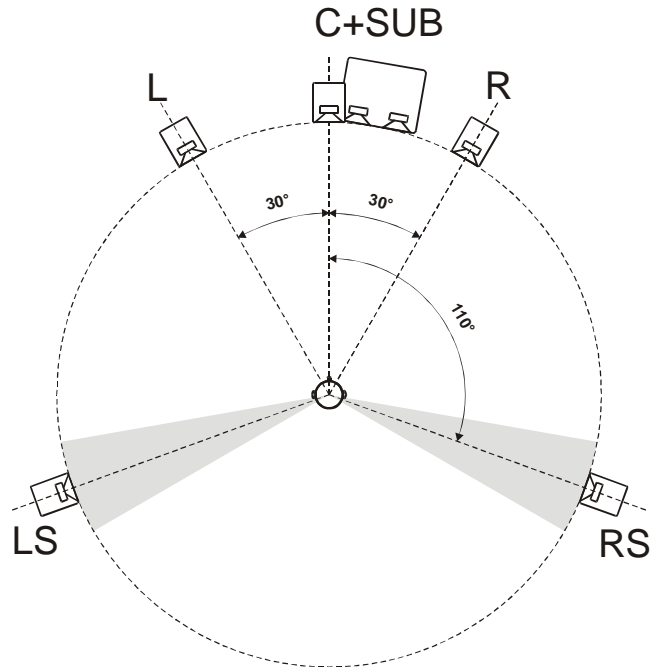

5+1 for music:

Acoustical center	Angle	Height
C	0°	1.2m
L,R	±30°	1.2m
LS,RS	±100-120°	≥1.2m
SUB	±10°	0m

Optimum subwoofer performance may be obtained by the use of two subwoofers

- **AV Applications (film & video)**

The standard Left / Right angle for film and TV is 45°. If your loudspeakers have to be installed behind a perforated screen, a 45° angle positioning will give the best results. For sound for picture applications, you may also consider a surround array of 4 (or more) surround speakers.

Recommended calibration levels are the following :

Left/right/Center : 75 dBC per channel

Surround Speaker : 72 dBC each

Subwoofer : for film mixing, the subwoofer level has an extra 10dB of headroom. This means that the subwoofer level should be calibrated accordingly i.e. 85 dB in band.

7 Troubleshooting

7.1 Power on LED does not light up.

Please check that the power switch is set on the ON position and that the mains cable is properly connected to the mains. If the problem persists, check the fuse, the voltage selector and the AC power voltage. If this still not solve the problem, contact PSI Audio or a PSI Audio authorised dealer.

7.2 Unbalanced to balanced operation

It can give rise to problems and special care should be taken in cabling.

7.3 Poor audio quality

Check the audio cabling to the speaker from the audio source, for poor wiring or broken connections.

7.4 Uneven frequency response

In the case of uneven frequency response, please check the performance of the loudspeaker with a known reference source (i.e. your favourite CD).

Loss of low frequencies

- Wrong phase or wiring
- Incorrect "Roll Off" calibration
- Wrong positioning in the room.

If performance still does not meet your expectations, please read the section about installation and calibration of your loudspeaker system to the acoustic environment.

8 C.E. & RoHS Conformities

PSI Audio products have been tested and calibrated according to the highest quality standards. An individual frequency response diagram is provided with each loudspeaker.

The PSI Audio products have been tested according to EU directives and amendments:

Low voltage directive (LVD), 2006/95/EC

Electromagnetic compatibility directive (EMC), 2004/108/EC

The relevant technical standards are:

EN 60065: 1998 Audio, video and similar apparatus – Safety requirements (Class 1)

EN 55103-1/E1: 1996 Product Standard – Emission
Audio, Video and audio-visual apparatus for professional use

EN 55103-2/E1: 1996 Product Standard – Immunity
Audio, Video and audio-visual apparatus for professional use



This product is manufactured according to the European directive 2002/95/EC

9 Warranty

Our products are guaranteed for 2 years against any manufacturing defects. Fair or wrong wear and tear are not covered by the warranty. We kindly remind the user that unauthorised servicing can void the warranty. In order to provide a quality service, we ask the user to always join the warranty card for each servicing.

If our goods are sent back to the manufacturer, the symptoms must be clearly mentioned. In case of warranty, the parts and labour costs are at the charge of the manufacturer. If no defect in workmanship is detected, the warranty is therefore not valid. A repair quotation will be sent and the relative lump cost will be charged to the customer.

For services (covered or not by warranty), the expenses and the risks of the transports both ways between the customer and his supplier are the responsibility and at the charge of the customer.

For any other provision, the Swiss code of obligations, Articles 197 to 210 will apply.
For any legal action, reference will apply to the Court of Yverdon (Switzerland) only.