

NOS

New Old Sound Ltd.

Pro Audio Gear Design Workshop

McOne Active ZenPro Edition Monitor Controller User Guide



Design and Functions
Features, Specs & Warranty
Block Diagram / Signal Flow

The New Old Sound McOne Active ZENPRO Edition is designed to be a desktop studio hub for all monitoring needs, delivering all the modern detail and nuances of your music as well as cue and talkback features, with a laid back vibe in appearance. A collaboration between Warren Dent (owner of ZenPro Audio) and Evgeny Klukin (owner of New Old Sound), we were able to combine popular feature requests with an elegant and modern design that is easy to use right out of the box. Each component, including Burr Brown amps, a high quality ALPS pot and smooth switches were carefully chosen based on function and sonics.

We have included explanations of features as well as a block diagram in this manual, in case you need to reference this info to best benefit your studio's workflow.

FUNCTIONS

- **INPUT A, B & C:** Selects three stereo TRS 1/4" inputs routed to OUTPUTS A, B & C and SUB
- **OUTPUT A, B & C:** Selects three stereo TRS 1/4" outputs for connection to three pairs of speakers
- **CUE SELECT A, B & C:** Choose from INPUTS A, B & C to feed the stereo CUE output separately (for headphone amps) regardless of what is playing back on the monitor pairs
- **MONO:** Sums the left and right stereo inputs to mono before the OUTPUTS A, B & C and SUB
- **SUB:** Switches the subwoofer output on and off, allowing you to check your mix with and without instantly
- **DIM:** Lowers signal output by -17dB to speaker OUTPUTS A, B & C and SUB
- **MUTE:** Silences audio to speaker OUTPUTS A, B & C and SUB
- **TALKBACK:** Engages built in microphone located next to switch and feeds the CUE OUT while dimming -17dB to OUTPUTS A, B & C and SUB (gain trim is located on bottom of unit)
- **POWER:** Turns the unit on (soft amber LED will glow) and off
- **VOLUME:** Raises and lowers volume to OUTPUTS A, B & C and SUB
- **HEADPHONE:** Raises and lowers volume to the 1/4" headphone jack on rear of the unit, receives input from INPUT A, B & C (same as the speaker outputs)
- **REAR CONNECTIONS:** 1/4" TRS is used for all audio connections in and out, will accept balanced or unbalanced signals as needed
- **POWER:** 2.1mm barrel connection, fed by included universal power supply

FEATURES

- Active balanced on all inputs and outputs
- Also accepts unbalanced signals from iPods, CD players, etc
- Clean, uncolored and detailed audio with uber flat response at all volumes
- Table top, ergonomic design is easy to reach for
- Cream color with black text is easy to read in dim lighting
- Wooden sides bring an old school vintage vibe to your DAW studio
- 3 Inputs, TRS 1/4" Balanced, Selectable for monitoring or CUE feed
- 3 Speaker Outputs, TRS 1/4" Balanced for multiple stereo pairs
- 1 Stereo Subwoofer Output, TRS 1/4" Balanced with on/off switch
- 1 Stereo CUE output, feed your artist headphone system with three inputs + talkback
- 1 Headphone output for control room / engineer
- Talkback microphone with talkback gain trim access on bottom of unit
- Volume pot, high quality ALPS
- Headphone amp volume control
- MONO summing for checking mixes, affects 3 speaker outs and subwoofer
- DIM function, -17dB value (engages during talkback)
- MUTE function
- Power switch with soft amber glow LED indicator
- Universal power supply, auto sensing (standard IEC 3 prong)

SPECIFICATIONS

- INPUT: Maximum Input Level +26dBu
- OUTPUT: Maximum Output Level before clipping +29dBu
- SIGNAL TO NOISE RATIO: @ 0dBu unity gain 120dB
- CROSSTALK: L/R @ 1kHz -105dBu
- THD & NOISE: unity gain +24dBu input .005%
- FREQUENCY RESPONSE: 20Hz-20kHz +/- 0.3dB
- DIMENSIONS: 10.25"W x 6"D x 3.25"H
- WEIGHT: 3.55 LBS (1.6 KG)
- POWER REQUIREMENTS: 12-18V @ 1000mA

ONE YEAR LIMITED WARRANTY

New Old Sound warrants that the Product conforms substantially to the specifications contained in the Product's documentation for a period of one (1) year from the date of original purchase. In the case of a valid warranty claim, New Old Sound's liability will be, at its option, to repair or replace the Product without charge or, if this is not possible, to refund the purchase price to you. For warranty service, please contact New Old Sound to obtain a Return Authorization (RA) number.

The Product is designed and manufactured for use in professional and studio audio systems and is not intended for other usage.

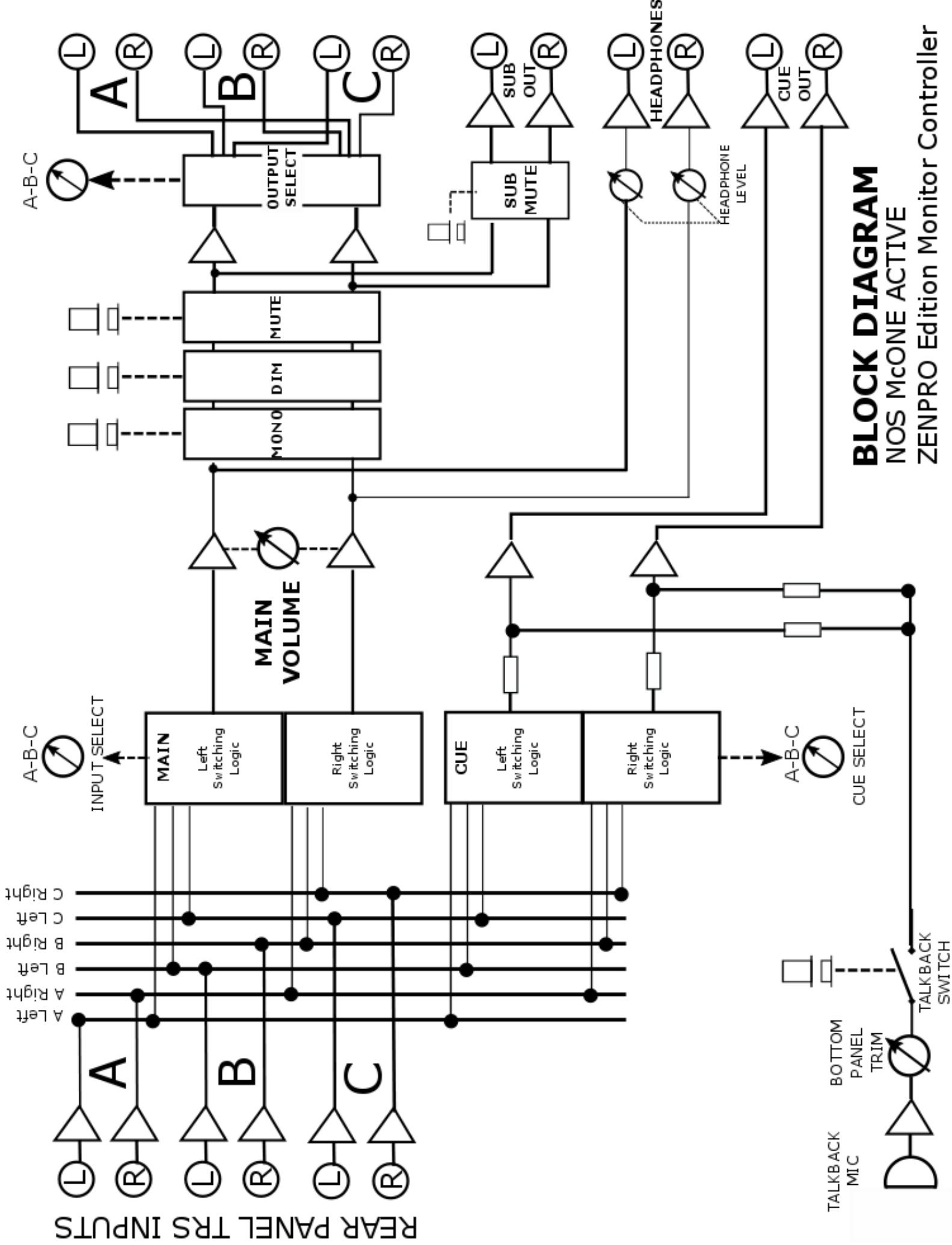

BLOCK DIAGRAM
 NOS McONE ACTIVE
 ZENPRO Edition Monitor Controller